

***3.3v Discrete Component Transceiver
For
Sital Technology's MIL-STD-1553 IP Cores***

***Rev 1.3
Jan 2008***

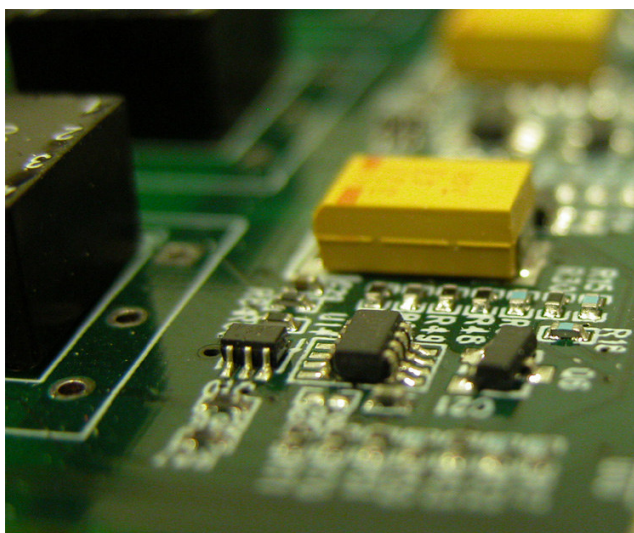

Sital Technology Ltd.
17 Atir Yeda St.
Kfar-Saba, **Israel**

Tel.: +972-9-7633300
Email: info@sital.co.il
www.sital.co.il

Copyright (C) 2005 by Sital Technology Ltd.

All rights reserved. No part of this document may be reproduced, stored in a retrieval system, or transmitted in any form, or by any means, electronic, mechanical, photocopying, recording, or otherwise, without the prior written permission of Sital Technology Ltd.



Table of Contents

Introduction	4
Block Diagram	5
Advantages	6

Introduction

The 3.3v Transceiver Design is an analog front-end interface solution developed by Sital Technology to interface between Sital's digital IP core and the MIL-STD-1553 transformer and bus.

The discrete component transceiver (DCT3v3) serves as an alternative to commonly available transceiver components.

The DCT3v3 was designed for transformer coupling method.

When purchasing the Transceiver Design, users can incorporate the design into their own board design and purchase the components from their suppliers. Users are provided with the design schematic, net-list, Bill-of-Material

(BOM) and PCB recommendations. Sital Technology does not provide the components. Only the design is provided. Users can purchase components from their local suppliers, in different form-factors, temperature ranges, grades and standards.

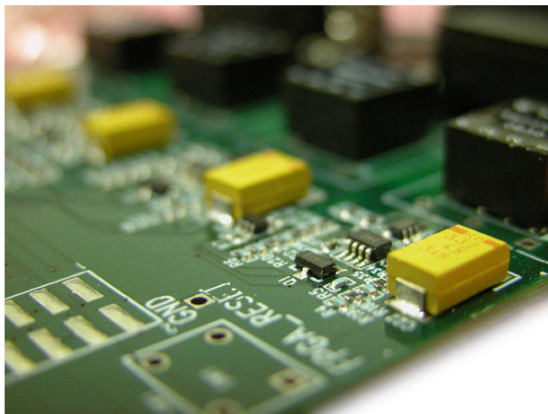

A 1553 transceiver is typically built from two parts, the digital part and the analog part.

The analog part both translates the digital transmit signals in to the proper analog voltages and currents to drive to a standard transformer and detect the analog signals from the transformer as defined by MIL-STD-1553B standard. The analog part was designed using state of the art analog components to provide space-optimized design, power efficiency and low cost.

The digital part is responsible for the signal shaping; over-load inhibit control and digital filtering of received signals as well as some other analog compensation. The digital part is supplied as part of Sital's 1553 IP cores. This digital part is very compact and efficient.

The DCT3v3 was developed with intensive analog and digital simulations to provide a robust design that can accommodate a variety of transformers and components but still deliver full compliance with MIL-STD-1553 standard.

Block Diagram

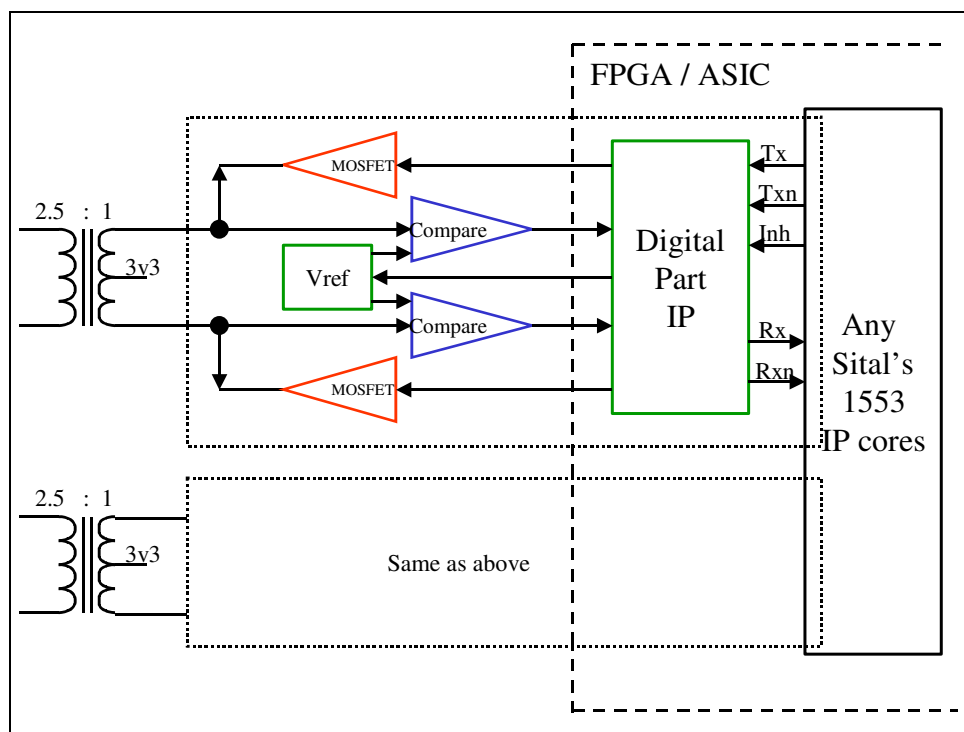

The transformer configuration is to have a center tap powered by the 3.3v power supply. The transformer's turn ratio should be a standard MIL-STD-1553 1:2.5 transformer. Each MOSFET driver pulls current in one half of the transformer, yielding an amplifying turn ratio of x5. The actual transformer voltage drop on each half is about 2v. When amplified by 5, the output transformer voltage of both halves is thus about 20v peek to peek.

The IP Digital core constantly monitors the MOSFET power drive, and if the transmitted power falls below a predefined threshold, as it does when the load is too high or shorted, the digital circuit cuts the transmission until end of message. If the bus wires are constantly shorted, the transmission circuit will try transmitting on every message for a short period of 500 ns, and then stop until next message. This procedure protects the strong MOSFET drivers from overload and potential damage.

The received signal is being compared to a predefined threshold proportional to bus signal of about 0.5v p-p which is below the standard's requirement of 0.86v p-p, and higher than the minimum detected signal at 0.2v p-p. The comparator also incorporates a noise filter to enhance the signal pickup in a noisy environment. Both the digital circuit IP and all of Sital's 1553 IPs incorporate additional noise filtering circuits that increases the noise proof above the 1553 standard's requirements.

Advantages

The DCT3v3 transceiver shows the following advantages over standard off-the-shelf transceivers:

- ❑ **Low cost** – The bill of materials (BOM) is very low, and is typically less than ¼ of a single component transceiver (~\$20).
- ❑ **Low power** – The transmitter is built around a very efficient MOSFET gate. It is either on or off. When on, its resistance (Rds-on) is very low, thus the power it needs to dissipate is less than 0.25 watt. The overall power during transmit is less than 0.5 watt. During receive, the power is just a few milliwatts.
- ❑ **Vendor independent** – The BOM is purchased by the end user and is composed of standard and common components, provided by any local distributor of components.
- ❑ **PCB Space** – although the total space that the DCT3v3 on the PCB might be bigger than a transceiver device, the components can be placed with great flexibility on both sides of the PCB, and in places where a transceiver device would not fit. Most of the BOM is composed of resistors and capacitors that can be as little as 0201.
- ❑ **Flexibility** – With a change in resistor values, the DCT3v3 can serve other bus standards, such as the French Digibus, which cannot be supported by a standard transceiver.
- ❑ **Availability** – The DCT3v3 is available today for testing. Sital delivers a PCB with the transceiver built on it, suitable for any evaluation board.
- ❑ **Input impedance** - The transceiver was carefully designed to provide high input impedance, higher than the minimum 1K ohm, required by the 1553 standard.



17 Atir Yeda St., Kfar-Saba, ISRAEL 44643

Email: info@sitaltech.com

Website: <http://www.sitaltech.com>

The information provided in this User's Guide is believed to be accurate; however, no responsibility is assumed by Sital Technology for its use, and no license or rights are granted by implication or otherwise in connection therewith. Specifications are subject to change without notice.

Please visit our Web site at www.sitaltech.com for the latest information.

© All rights reserved. No part of this User's Guide may be reproduced or transmitted in any form or by any means, electronic, mechanical, photocopying, recording, or otherwise, without the prior written permission by Sital Technology.