

# ARINC 429 IP Core for FPGAs



## ARINC429IP

A simple ARINC 429 IP Core  
with modular transmitters and  
receivers

Compact, Robust, Reliable  
MIL-STD-IP-Cores

### Key Features and Benefits

- ARINC 429 specification compatible
- Separated channels for ARINC 429 Data Transmit and Receive
- 32 bits wide, programmable depth, separated FIFO buffers for transmit and receive
- Configurable transmission baud rate
- Programmable parity: Even, Odd or No-parity (32<sup>nd</sup> bit as data)
- FIFO full/empty indication
- Supports Standard Line Drivers
- Works with almost any clock frequency
- Small FPGA area utilization
- Modular architecture allowing flexible implementations. Any number of transmitters and receivers available in a single Netlist.
- Provided with full verification environment
- Based on vendor and technology independent VHDL code

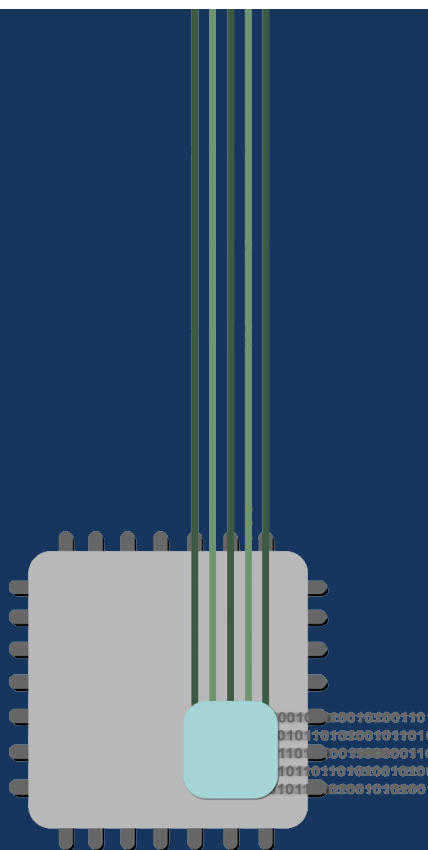

### More products from Sital:

- MIL-STD-1553 IP Core, DDC® compatible with local bus interface
- MIL-STD-1553 IP Cores for simple BC/RT/MT Applications.
- MIL-STD-1553 Discrete Components Transceiver
- MIL-STD-1553 Testers.
- MIL-STD-1553 Design Services
- ARINC 429 IP Core
- PCI IP core

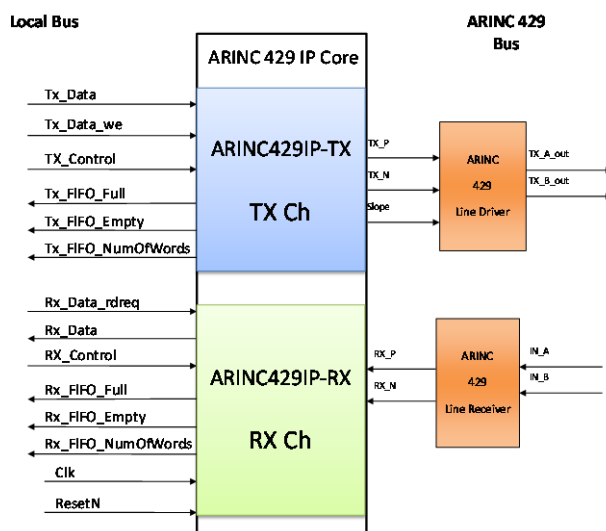

Designed from ground up for use in aerospace, avionics and military, Sital's IP products, offer uniquely compact, robust and reliable solutions for any PLD/FPGA and ASIC device.

## Supported FPGAs

- Any FPGA with sufficient number of LUTs and Dual-Port memory
- FPGA families from the following vendors:
  - Xilinx
  - Altera
  - Lattice
  - Actel

\* For other FPGAs or ASIC please consult Sital

## ARINC429IP Deliverables

- EDIF net list for the desired core (BC/RT/MT) for FPGA family and memory
- User's manual
- Sample VHDL code that incorporates the core
- Synthesis script for sample code

## Available Configurations

- **ARINC429IP-TX**: ARINC 429 transmitter
- **ARINC429IP-RX**: ARINC 429 receiver
- **ARINC429IP-TX-n-RX-m**: ARINC429, 'n' transmitters and 'm' receivers

## ARINC 429 Tx/Rx Core Operation

The ARINC429IP Core is divided between two independent modules for transmit (ARINC429IP-TX) and receive (ARINC429IP-RX).

A user can order any combination of transmitters and receivers which are packaged under the same FPGA netlist.

Each ARINC 429 channel (Rx / Tx) have a 32bits wide FIFO memory. (FIFO depth may be set during synthesis by Sital. Default value is 64 words).

### ARINC 429 Transmitter

Whenever a data is written into to the Tx\_FIFO, the **ARINC429IP-TX** Core will start transmitting this data to the serial Tx ports based on the Tx channel control register configuration. Data will be transmitted consequentially word after word until the Tx\_FIFO will become empty.

Tx\_FIFO status (Empty/Full) and Number\_Of\_Words are reported in the dedicated ports. Once FIFO\_Full is asserted, there is no option to write new words to the Tx\_FIFO.

### ARINC 429 Receiver

The **ARINC429IP-RX** Core receives data from the ARINC 429 bus and converts it to the local bus. This core is responsible for recovering the clock from the input serial data and performs serial-to-parallel conversion and gap/parity check on the incoming data.

The received ARINC 32-bit word is checked for correct decoding and label matching (based on the label-compare bit and the SDI-compare bit in the Control Register) before loaded into the Rx\_FIFO. ARINC words which do not meet the necessary matching ignored and are not loaded into the FIFO.

## Advanced Verification

To ensure a fully reliable and robust product the core was developed using an advanced verification environment that includes a Random-Generation engine, Code-Coverage and assertion tools.

All ARINC429 functions and performance requirements were verified.

## DO-254 Compliance

The ARINC429IP Core was developed with DO-254 requirements in mind.

Requirements are traceable to the code. Development done using design tools from Mentor Graphics – HDL Designer, Modelsim, Precision and ReqTracer.

## Simple Integration

In order to simplify the integration of the core, a sample VHDL design that uses the core is provided, including:

- A comprehensive user's manual.
- A VHDL gate level model of the core for the target technology.
- A Transceiver VHDL model that connects the core with 2 buses.
- A bus tester VHDL model that generates ARINC 429 messages and checks the return replies.
- A top Test bench that instantiates all of these components to a working example.
- A simulation script for compiling and running the core.

## Sital Technology Ltd.

Tel: +972-9-7633300  
Fax: +972-9-7663394

Email: info@sitaltech.com  
Web: www.sitaltech.com



## About Sital Technology

Founded in 1993, Sital Technology is a leading provider of IP cores and products for Mil-Std-1553, ARINC 429 and Can bus.

SITAL Technology's key quality resource is its creative, talented and professional staff. Our engineers are veterans of the Israeli Air Force, who served in the technical units of the F-16 avionics systems. They gained knowledge and experience with the MIL-STD-1553 standard from the bottom up, both as design engineers for MIL-STD-1553 components and as technicians working on the aircrafts.

Among our many customers you can find NASA, Israeli Aircraft Industries (IAI), Rafael, Elbit, Astronautics, Tadiran, Israeli Ministry of Defense, Elta, Honeywell, BAE Systems, RADA and many others.

Represented in USA by:

